

General Purpose Relay G7J

- Ideal for 3-phase motor control applications and resistive and inductive loads.
- No contact chattering for momentary voltage drops up to 50% of rated voltage.
- Withstands more than 4 kV between contacts that are of different polarity and between the coil and contacts.
- Flame-resistant materials (UL94V-0) used for all insulation.
- Push-to-test button on all models lets user check contact operation.
- Class B coil insulation available.

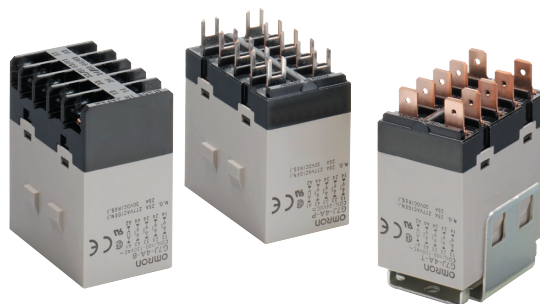

Ordering Information

Type	Contact form	Model		
		Quick-connect terminal	Screw terminal	PCB terminal
PCB mounting	4PST-NO	—	—	G7J-4A-P, G7J-4A-PZ
	3PST-NO/SPST-NC	—	—	G7J-3A1B-P, G7J-3A1B-PZ
	DPST-NO/DPST-NC	—	—	G7J-2A2B-P
W-bracket (see note)	4PST-NO	G7J-4A-T, G7J-4A-TZ	G7J-4A-B	
	3PST-NO/SPST-NC	G7J-3A1B-T, G7J-3A1B-TZ	G7J-3A1B-B, G7J-3A1B-BZ	
	DPST-NO/DPST-NC	G7J-2A2B-T	G7J-2A2B-B	

Note: The G7J relays require a W-bracket for mounting. Order the bracket separately below. To order a relay and bracket packed together, add “-W1” to the part number before the coil voltage suffix. For example, G7J-2A2B-B-W1-AC100/120.

Model Number Legend

To Order: Select the part number and add the desired coil voltage rating (e.g., G7J-3A1B-B-AC100/120).

G7J - - -

1 2 3

1. Contact Form

- 4A: 4PST-NO
- 3A1B: 3PST-NO/SPST-NC
- 2A2B: DPST-NO/DPST-NC

2. Terminal Shape

- P: PCB terminals
- B: Screw terminals
- T: Quick-connect terminals (#250 terminal)

3. Contact Structure

- Z: Bifurcated contact
- None: Single contact

Note: For bifurcated contact type, output is 1NO (4PST-NO) or 1NC (3PST-NO/SPST-NC).

Accessories

Types	Applicable relays	Model
W-brackets	G7J-4A-B, G7J-3A1B-B(Z), G7J-2A2B-B, G7J-4A-T(Z), G7J-3A1B-T, G7J-2A2B-T	R99-04-FOR-G5F

Typical Applications

Compressors for air conditioners and heater switching controllers.

Switching controllers for power tools or motors.

Lamp controls, motor drivers, and power supply switching controllers in copy machines, facsimile machines, and other office equipment.

Power controllers for packers or food processing equipment.

Power controllers for inverters.

Specifications

■ Contact Data

Load	Resistive load (p.f. = 1)	
	NO	NC
Rated load	25 A @ 220 VAC (1 A @ 220 VAC) / 25 A @ 30 VDC	8 A @ 220 VAC (1 A @ 220 VAC)/ 8 A @ 30 VDC
Rated carry current	25 A (1 A)	8 A (1 A)
Max. switching voltage	250 VAC, 125 VDC	
Max. switching current	25 A (1 A)	8 A (1A)
Max. switching capacity	5,500 VA, 750 W DC	1,760 VA, 240 W DC
Min. permissible load	100 mA @ 24 VDC (10 mA @ 24 VDC) at 60 operations/minute, 23°C ambient temperature (See note 2)	

Note: 1. The values in parentheses indicate values for a bifurcated contact.

2. P level: $\lambda_{60} = 0.1 \times 10^{-6}$ /operations

■ Coil Data

Rated voltage (VAC)	Rated current (mA)	Coil resistance (Ω)	Must operate	Must release	Max. voltage	Power consumption
			% of rated voltage			
AC	24	75	75% max.	15% min.	110% @ 23°C	Approx. 1.8 to 2.6 VA
	50	36				
	100/120	18 to 21.60				
	200/240	9 to 10.80				
DC	12	167	72	10% min.		Approx. 2.0 W
	24	83				
	48	42				
	100	20				

Note: 1. The rated current and coil resistance are measured at a coil temperature of 23°C with tolerances of +15%/-20% for AC rated current and $\pm 15\%$ for DC coil resistance. The values given for AC rated current apply at 50 Hz or 60 Hz.

2. Performance characteristic data are measured at a coil temperature of 23°C.

■ Characteristics

Contact resistance (See note 2)	50 m Ω max.	
Operating time (See note 3)	50 ms max.	
Release time (See note 3)	50 ms max.	
Operating frequency	Mechanical	1,800 operations/hour max.
	Electrical	1,800 operations/hour max.
Insulation resistance (See note 4)	1,000 M Ω minimum at 500 VDC	
Dielectric strength	4,000 VAC, 50/60 Hz for 1 minute between coil and contacts	
	4,000 VAC, 50/60 Hz for 1 minute between contacts of different polarity	
	2,000 VAC, 50/60 Hz for 1 minute between contacts of the same polarity	
Impulse withstand voltage	10,000 V between coil and contact with 1.2 x 50 μ s impulse wave	
Vibration	Mechanical durability	10 to 55 Hz, 1.50 mm double amplitude
	Malfunction durability	NO: 10 to 55 Hz, 1.50 mm double amplitude NC: 10 to 26 Hz, 1.50 mm double amplitude
Shock	Mechanical durability	1000 m/s ² (Approx. 100 G)
	Malfunction durability	NO: 100 m/s ² (Approx. 10 G) NC: 20 m/s ² (Approx. 2 G)
Service life	Mechanical	1 million operations minimum at 1,800 operations/hour
	Electrical	100,000 operations minimum at 1,800 operations/hour at rated load (@ 23°C)
Ambient temperature	Operating	-25° to 60°C with no icing or condensation
Humidity	Operating	5% to 85% RH
Weight	PCB terminal	Approx. 140 g
	Screw terminal	Approx. 165 g

Note: 1. Data shown are of initial value.

2. Measured with 1A @ 5 VDC using the voltage drop method.

3. Measured with rated voltage imposed, ignoring any contact bounce, at ambient temperature = 23°C.

4. Measured with a 500-VDC megger applied to the same places as those used for checking the dielectric strength.

Engineering Data

Maximum Switching Power

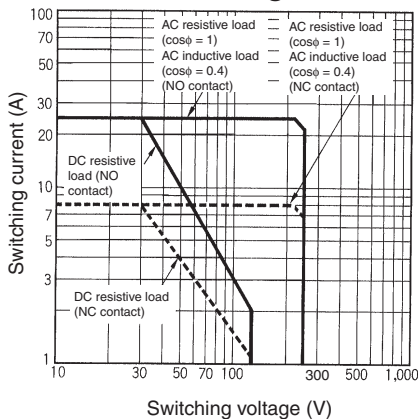

Endurance

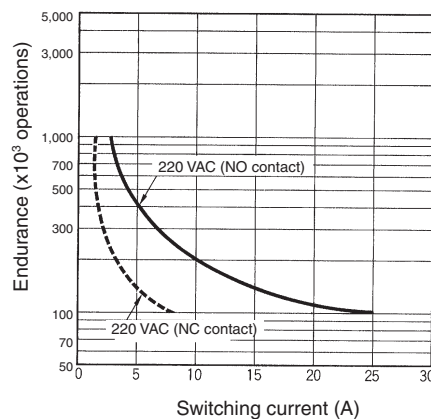

Malfunctioning Shock

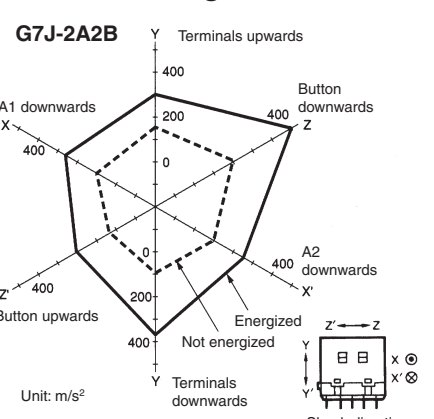

Number of samples: 5
 Measurement conditions: Increase and decrease the specified shock gradually imposed in ±X, ±Y, and ±Z directions three times each with the Relay energized and not energized to check the shock values that cause the Relay to malfunction.
 Criteria: There must not be any contact separation for 1 ms or greater with a shock of 100 m/s² imposed when the coil is energized or with a shock of 20 m/s² when the coil is not energized.

Ambient Temperature vs. Must-operate and Must-release Voltage

G7J 100 to 120 VAC

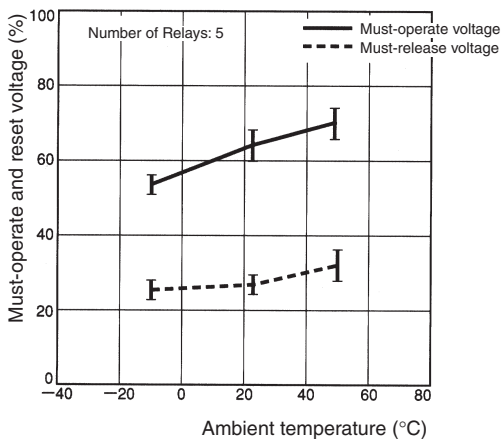

Ambient Temperature vs. Coil Temperature Rise

G7J-4A 100 to 120 VAC

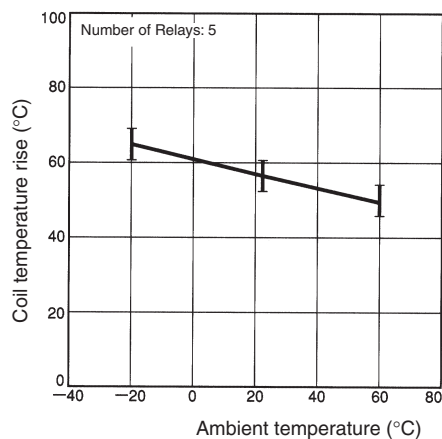

G7J 24 VDC

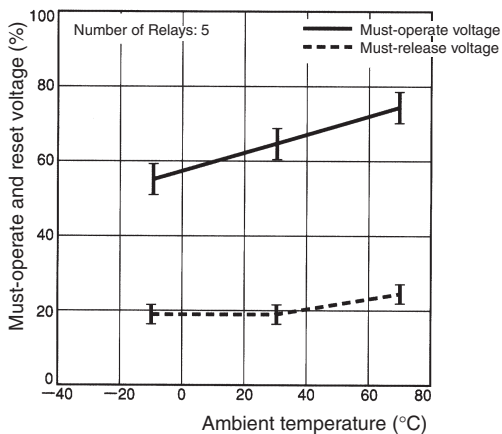

G7J-4A 24 VDC

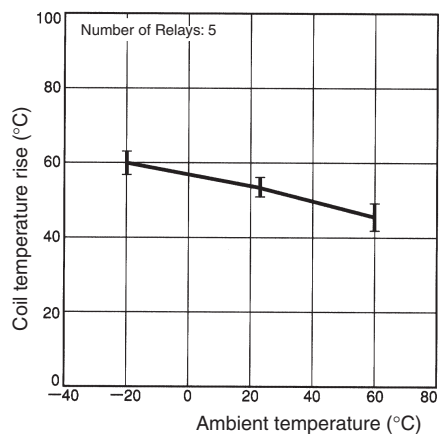

Motor Load Performance

Item	G7J-4A-P, G7J-3A1B-P, G7J-4A-B, G7J-3A1B-B, G7J-4A-T, G7J-3A1B-T
Load	3φ, 220 VAC, 2.7 kW (with a inrush current of 78 A and a breaking current of 13 A)
Endurance	Electrical: 100,000 operations min.

Dimensions

Note: All units are in millimeters unless otherwise indicated

Screw Terminals with W-bracket

G7J-4A-B, G7J-3A1B-B, G7J-3A1B-BZ, G7J-2A2B-B

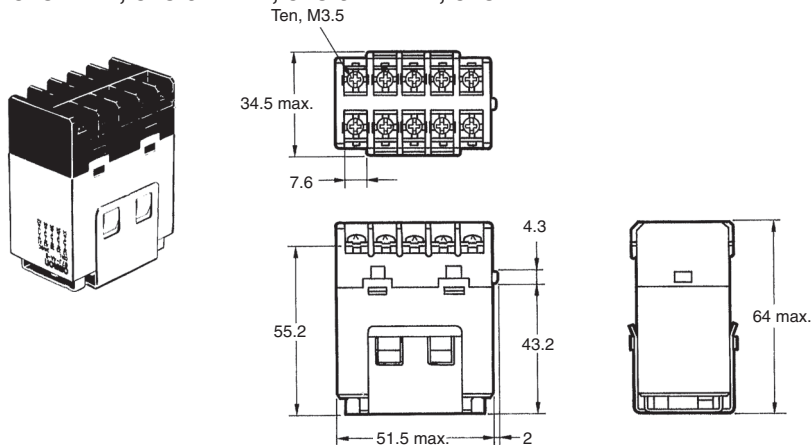

Mounting Holes

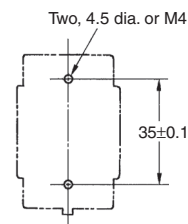

Quick-connect Terminals with W-bracket

G7J-4A-T, G7J-4A-TZ, G7J-3A1B-T, G7J-2A2B-T

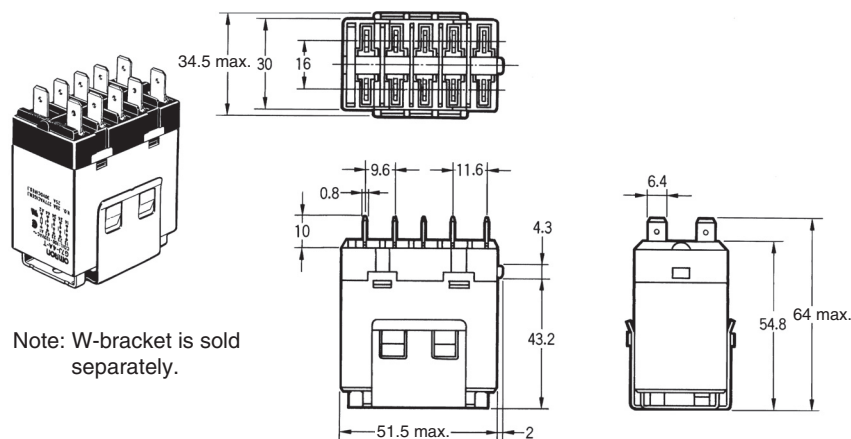

Mounting Holes

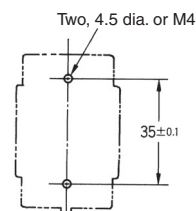

Note: W-bracket is sold separately.

PCB Terminals with PCB Mounting

G7J-4A-P, G7J-4A-PZ, G7J-3A1B-P, G7J-3A1B-PZ, G7J-2A2B-P

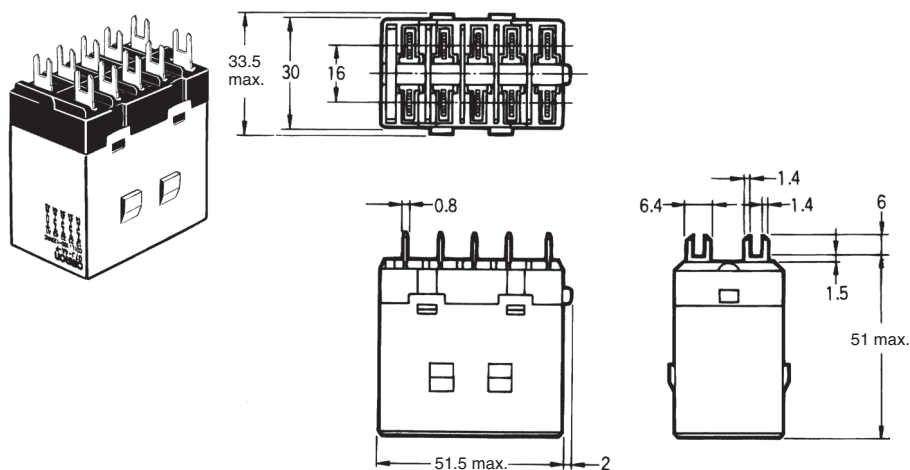

Mounting Dimensions

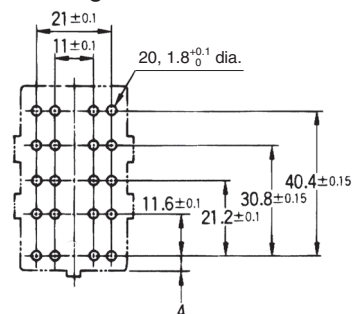

Terminal Arrangement/Internal Connections

G7J-4A-P
G7J-4A-B
G7J-4A-T

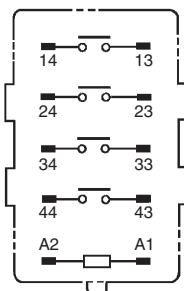

G7J-3A1B-P
G7J-3A1B-B
G7J-3A1B-T

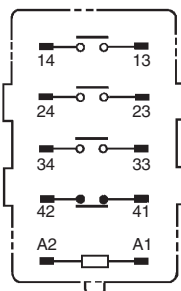

G7J-2A2B-P
G7J-2A2B-B
G7J-2A2B-T

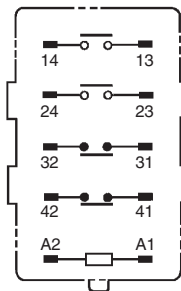

Note: Terminals 43 and 44 of the G7J-4A-P(T) and contacts 41 and 42 of the G7J-3A1B-P(B) are bifurcated contacts.

The coil has no polarity.

Accessories (Order Separately)

R99-04 W-bracket (for G5F)

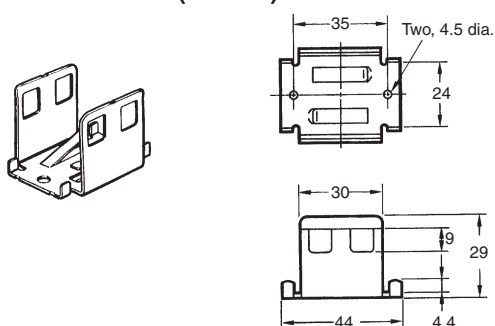

Mounting Holes

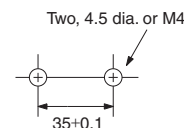

Approvals

Note: 1. The rated values approved by each of the safety standards may be different from the performance characteristics individually defined in this catalog.
2. In the interest of product improvement, specifications are subject to change without notice.

UL Recognized (File No. E41643) / CSA Certified (File No. LR 35535) - - Ambient Temp = 40°C

Coil ratings	Contact ratings		Number of test operations	
24 to 265 VAC 6 to 110 VDC	NO contact	25 A 277 VAC, Resistive	30,000	
		25 A 120 VAC, General Use		
		25 A 277 VAC, General Use		
		25 A 240 VAC, General Use	100,000	
		1.5 kW 120 VAC, Tungsten		
		1.5 hp 120 VAC		
		3 hp 240/265/277 VAC	30,000	
		3-phase 3 hp 240/265/277 VAC		
		3-phase 5 hp 240/265/277 VAC		
		20FLA/120LRA 120 VAC		
		17FLA/102LRA 277 VAC		
		TV-10 120 VAC		25,000
		NC contact	25 A 30 VDC, Resistive	30,000
			*1 A 277 VAC, General Use	6,000
			8 A 277 VAC, Resistive	30,000
	8 A 120 VAC, General Use			
	8 A 277 VAC, General Use			
	8 A 30 VDC, Resistive			
*1 A 277 VAC, General Use	6,000			

Note: *These ratings are bifurcated contact ratings.

Reference

UL approval: UL508 for industrial control devices
 UL1950 for information processing equipment including business machines
 CSA approval: CSA C22.2 No. 14 for industrial control devices
 CSA C22.2 No. 950 for information processing equipment including business machines

VDE - EN60255-1-00: 1997 and EN60255-23: 1996(File No. 5381UG)

Model	Coil ratings	Contact ratings	
		NO contact	NC contact
G7J-4A-B(P) (T)	6, 12, 24, 48, 100 VDC	25 A 240 VAC $\cos\phi = 0.4$	8 A 240 VAC $\cos\phi = 0.4$
G7J-2A2B(P) (T)	24, 50, 100 to 120, 200 to 240 VAC	25 A 240 VAC $\cos\phi = 1$	8 A 240 VAC $\cos\phi = 1$
G7J-3A1B-B(P) (T)		25 A 30 VDC $L/R \geq 1$	8 A 30 VDC $L/R \geq 1$

Note: Add the suffix “-KM” to the model number when ordering.

KEMA - EN60947-4-1 and IEC947-4-1 for contacts (File No. 2001291.02)

Model	Coil ratings	Contact ratings - NO contact
G7J-4A-B(P) (T) (Z) G7J-2A2B(P) (T)	200 to 240 VAC	Class AC1: 25 A at 220 VAC 11.5 A at 380 to 480 VAC
G7J-3A1B-B(P) (T) (Z)	6, 12, 24, 48, 100 VDC 24, 50, 100 to 120, 200 to 240 VAC	Class AC3: 11.5 A at 220 VAC and 8.5 A at 380 to 480 VAC *Class AC1: 1 A at 220 VAC

Note: Add the suffix “-KM” to the model number when ordering. *This rating is the bifurcated contact rating.

Precautions

Note: Be sure to read the precautions and information common to all relays, contained in the Technical User's Guide, “Electromechanical Relays - Technical Information”, for correct use.

Correct Use

Installation

PCB Terminal-equipped Relays weigh approximately 140 g. Be sure that the PCB is strong enough to support them. We recommend dual-side through-hole PCBs to reduce solder cracking from heat stress.

Mount the G7J with its test button facing downwards. The Relay may malfunction due to shock if the test button faces upwards. Be careful not to press the test button by mistake because the contacts will go ON if the test button is pressed.

Be sure to use the test button for test purposes only. The test button is used for Relay circuit tests, such as a circuit continuity test. Do not attempt to switch the load with the test button. If a voltage is applied to the coil, the test button will retract in an ON state (i.e., an excited state).

Micro Loads

The G7J is used for switching power loads, such as motor, transformer, solenoid, lamp, and heater loads. Do not use the G7J for switching minute loads, such as signals. Use a Relay with a bifurcated contact construction for switching micro loads, in which case, however, only SPST-NO or SPST-NC output is obtained.

Soldering PCB Terminals

Be sure to solder the PCB terminals manually only. In the case of automatic soldering, some flux may stick to the test button and the G7J. As a result, the G7J may malfunction.

The G7J is not of enclosed construction. Therefore, do not wash the G7J with water or any detergent.

Connecting

Refer to the following diagram when connecting a wire with a screw terminal to the G7J.

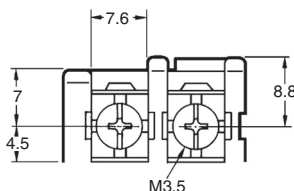

Allow suitable slack on leads when wiring, and do not subject the terminals to excessive force.

Tightening torque: 0.98 N·m

Do not impose excessive external force on the G7J in the horizontal or vertical directions when inserting the G7J to the Faston receptacle or pulling the G7J out from the Faston receptacle. Do not attempt to insert or pull out more than one G7J Unit together.

Do not solder the tab terminals.

Operating Coil Internal Connections of Coils

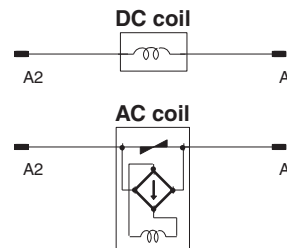

If a transistor drives the G7J, check the leakage current, and connect a bleeder resistor if necessary.

The AC coil is provided with a built-in full-wave rectifier that prevents contact chatter during a voltage drop. This circuit allows the relays to withstand, with no vibration or shock, voltage drops to the coil of up to 50% of the rated coil voltage for 1 second max.

If a triac, such as an SSR, drives the AC coil of the G7J, the G7J may not release. Be sure to perform a trial operation with the G7J and the triac before applying them to actual use.

Terms and Conditions of Sale

1. **Offer; Acceptance.** These terms and conditions (these "Terms") are deemed part of all quotes, agreements, purchase orders, acknowledgments, price lists, catalogs, manuals, brochures and other documents, whether electronic or in writing, relating to the sale of products or services (collectively, the "Products") by Omron Electronics LLC and its subsidiary companies ("Omron"). Omron objects to any terms or conditions proposed in Buyer's purchase order or other documents which are inconsistent with, or in addition to, these Terms.
2. **Prices; Payment Terms.** All prices stated are current, subject to change without notice by Omron. Omron reserves the right to increase or decrease prices on any unshipped portions of outstanding orders. Payments for Products are due net 30 days unless otherwise stated in the invoice.
3. **Discounts.** Cash discounts, if any, will apply only on the net amount of invoices sent to Buyer after deducting transportation charges, taxes and duties, and will be allowed only if (i) the invoice is paid according to Omron's payment terms and (ii) Buyer has no past due amounts.
4. **Interest.** Omron, at its option, may charge Buyer 1-1/2% interest per month or the maximum legal rate, whichever is less, on any balance not paid within the stated terms.
5. **Orders.** Omron will accept no order less than \$200 net billing.
6. **Governmental Approvals.** Buyer shall be responsible for, and shall bear all costs involved in, obtaining any government approvals required for the importation or sale of the Products.
7. **Taxes.** All taxes, duties and other governmental charges (other than general real property and income taxes), including any interest or penalties thereon, imposed directly or indirectly on Omron or required to be collected directly or indirectly by Omron for the manufacture, production, sale, delivery, importation, consumption or use of the Products sold hereunder (including customs duties and sales, excise, use, turnover and license taxes) shall be charged to and remitted by Buyer to Omron.
8. **Financial.** If the financial position of Buyer at any time becomes unsatisfactory to Omron, Omron reserves the right to stop shipments or require satisfactory security or payment in advance. If Buyer fails to make payment or otherwise comply with these Terms or any related agreement, Omron may (without liability and in addition to other remedies) cancel any unshipped portion of Products sold hereunder and stop any Products in transit until Buyer pays all amounts, including amounts payable hereunder, whether or not then due, which are owing to it by Buyer. Buyer shall in any event remain liable for all unpaid accounts.
9. **Cancellation; Etc.** Orders are not subject to rescheduling or cancellation unless Buyer indemnifies Omron against all related costs or expenses.
10. **Force Majeure.** Omron shall not be liable for any delay or failure in delivery resulting from causes beyond its control, including earthquakes, fires, floods, strikes or other labor disputes, shortage of labor or materials, accidents to machinery, acts of sabotage, riots, delay in or lack of transportation or the requirements of any government authority.
11. **Shipping; Delivery.** Unless otherwise expressly agreed in writing by Omron:
 - a. Shipments shall be by a carrier selected by Omron; Omron will not drop ship except in "break down" situations.
 - b. Such carrier shall act as the agent of Buyer and delivery to such carrier shall constitute delivery to Buyer;
 - c. All sales and shipments of Products shall be FOB shipping point (unless otherwise stated in writing by Omron), at which point title and risk of loss shall pass from Omron to Buyer; provided that Omron shall retain a security interest in the Products until the full purchase price is paid;
 - d. Delivery and shipping dates are estimates only; and
 - e. Omron will package Products as it deems proper for protection against normal handling and extra charges apply to special conditions.
12. **Claims.** Any claim by Buyer against Omron for shortage or damage to the Products occurring before delivery to the carrier must be presented in writing to Omron within 30 days of receipt of shipment and include the original transportation bill signed by the carrier noting that the carrier received the Products from Omron in the condition claimed.
13. **Warranties.** (a) **Exclusive Warranty.** Omron's exclusive warranty is that the Products will be free from defects in materials and workmanship for a period of twelve months from the date of sale by Omron (or such other period expressed in writing by Omron). Omron disclaims all other warranties, express or implied. (b) **Limitations.** OMRON MAKES NO WARRANTY OR REPRESENTATION, EXPRESS OR IMPLIED, ABOUT NON-INFRINGEMENT, MERCHANTABILITY OR FITNESS FOR A PARTICULAR PURPOSE OF THE PRODUCTS. BUYER ACKNOWLEDGES THAT IT ALONE HAS DETERMINED THAT THE PRODUCTS WILL SUITABLY MEET THE REQUIREMENTS OF THEIR INTENDED USE. Omron further disclaims all warranties and responsibility of any type for claims or expenses based on infringement by the Products or otherwise of any intellectual property right. (c) **Buyer Remedy.** Omron's sole obligation hereunder shall be, at Omron's election, to (i) replace (in the form originally shipped with Buyer responsible for labor charges for removal or replacement thereof) the non-complying Product, (ii) repair the non-complying Product, or (iii) repay or credit Buyer an amount equal to the purchase price of the non-complying Product; provided that in no event shall Omron be responsible for warranty, repair, indemnity or any other claims or expenses regarding the Products unless Omron's analysis confirms that the Products were properly handled, stored, installed and maintained and not subject to contamination, abuse, misuse or inappropriate modification. Return of any Products by Buyer must be approved in writing by Omron before shipment. Omron Companies shall not be liable for the suitability or unsuitability or the results from the use of Products in combination with any electrical or electronic components, circuits, system assemblies or any other materials or substances or environments. Any advice, recommendations or information given orally or in writing, are not to be construed as an amendment or addition to the above warranty. See <http://www.omron247.com> or contact your Omron representative for published information.
14. **Limitation on Liability; Etc.** OMRON COMPANIES SHALL NOT BE LIABLE FOR SPECIAL, INDIRECT, INCIDENTAL, OR CONSEQUENTIAL DAMAGES, LOSS OF PROFITS OR PRODUCTION OR COMMERCIAL LOSS IN ANY WAY CONNECTED WITH THE PRODUCTS, WHETHER SUCH CLAIM IS BASED IN CONTRACT, WARRANTY, NEGLIGENCE OR STRICT LIABILITY. Further, in no event shall liability of Omron Companies exceed the individual price of the Product on which liability is asserted.
15. **Indemnities.** Buyer shall indemnify and hold harmless Omron Companies and their employees from and against all liabilities, losses, claims, costs and expenses (including attorney's fees and expenses) related to any claim, investigation, litigation or proceeding (whether or not Omron is a party) which arises or is alleged to arise from Buyer's acts or omissions under these Terms or in any way with respect to the Products. Without limiting the foregoing, Buyer (at its own expense) shall indemnify and hold harmless Omron and defend or settle any action brought against such Companies to the extent based on a claim that any Product made to Buyer specifications infringed intellectual property rights of another party.
16. **Property; Confidentiality.** Any intellectual property in the Products is the exclusive property of Omron Companies and Buyer shall not attempt to duplicate it in any way without the written permission of Omron. Notwithstanding any charges to Buyer for engineering or tooling, all engineering and tooling shall remain the exclusive property of Omron. All information and materials supplied by Omron to Buyer relating to the Products are confidential and proprietary, and Buyer shall limit distribution thereof to its trusted employees and strictly prevent disclosure to any third party.
17. **Export Controls.** Buyer shall comply with all applicable laws, regulations and licenses regarding (i) export of products or information; (ii) sale of products to "forbidden" or other proscribed persons; and (iii) disclosure to non-citizens of regulated technology or information.
18. **Miscellaneous.** (a) **Waiver.** No failure or delay by Omron in exercising any right and no course of dealing between Buyer and Omron shall operate as a waiver of rights by Omron. (b) **Assignment.** Buyer may not assign its rights hereunder without Omron's written consent. (c) **Law.** These Terms are governed by the law of the jurisdiction of the home office of the Omron company from which Buyer is purchasing the Products (without regard to conflict of law principles). (d) **Amendment.** These Terms constitute the entire agreement between Buyer and Omron relating to the Products, and no provision may be changed or waived unless in writing signed by the parties. (e) **Severability.** If any provision hereof is rendered ineffective or invalid, such provision shall not invalidate any other provision. (f) **Setoff.** Buyer shall have no right to set off any amounts against the amount owing in respect of this invoice. (g) **Definitions.** As used herein, "including" means "including without limitation"; and "Omron Companies" (or similar words) mean Omron Corporation and any direct or indirect subsidiary or affiliate thereof.

Certain Precautions on Specifications and Use

1. **Suitability of Use.** Omron Companies shall not be responsible for conformity with any standards, codes or regulations which apply to the combination of the Product in the Buyer's application or use of the Product. At Buyer's request, Omron will provide applicable third party certification documents identifying ratings and limitations of use which apply to the Product. This information by itself is not sufficient for a complete determination of the suitability of the Product in combination with the end product, machine, system, or other application or use. Buyer shall be solely responsible for determining appropriateness of the particular Product with respect to Buyer's application, product or system. Buyer shall take application responsibility in all cases but the following is a non-exhaustive list of applications for which particular attention must be given:
 - (i) Outdoor use, uses involving potential chemical contamination or electrical interference, or conditions or uses not described in this document.
 - (ii) Use in consumer products or any use in significant quantities.
 - (iii) Energy control systems, combustion systems, railroad systems, aviation systems, medical equipment, amusement machines, vehicles, safety equipment, and installations subject to separate industry or government regulations.
 - (iv) Systems, machines and equipment that could present a risk to life or property. Please know and observe all prohibitions of use applicable to this Product.

NEVER USE THE PRODUCT FOR AN APPLICATION INVOLVING SERIOUS RISK TO LIFE OR PROPERTY OR IN LARGE QUANTITIES WITHOUT ENSURING THAT THE SYSTEM AS A WHOLE HAS BEEN DESIGNED TO ADDRESS THE RISKS, AND THAT THE OMRON'S PRODUCT IS PROPERLY RATED AND INSTALLED FOR THE INTENDED USE WITHIN THE OVERALL EQUIPMENT OR SYSTEM.
2. **Programmable Products.** Omron Companies shall not be responsible for the user's programming of a programmable Product, or any consequence thereof.
3. **Performance Data.** Data presented in Omron Company websites, catalogs and other materials is provided as a guide for the user in determining suitability and does not constitute a warranty. It may represent the result of Omron's test conditions, and the user must correlate it to actual application requirements. Actual performance is subject to the Omron's Warranty and Limitations of Liability.
4. **Change in Specifications.** Product specifications and accessories may be changed at any time based on improvements and other reasons. It is our practice to change part numbers when published ratings or features are changed, or when significant construction changes are made. However, some specifications of the Product may be changed without any notice. When in doubt, special part numbers may be assigned to fix or establish key specifications for your application. Please consult with your Omron's representative at any time to confirm actual specifications of purchased Product.
5. **Errors and Omissions.** Information presented by Omron Companies has been checked and is believed to be accurate; however, no responsibility is assumed for clerical, typographical or proofreading errors or omissions.

Note: This datasheet is provided as a guideline for selecting products. Do not use this document to operate the Unit.

ALL DIMENSIONS SHOWN ARE IN MILLIMETERS.

To convert millimeters into inches, multiply by 0.03937. To convert grams into ounces, multiply by 0.03527.

OMRON

OMRON ELECTRONICS LLC • THE AMERICAS HEADQUARTERS

Schaumburg, IL USA • 847.843.7900 • 800.556.6766 • www.omron247.com

OMRON CANADA, INC. • HEAD OFFICE

Toronto, ON, Canada • 416.286.6465 • 866.986.6766 • www.omron247.com

OMRON ELETRÔNICA DO BRASIL LTDA • HEAD OFFICE

São Paulo, SP, Brasil • 55.11.2101.6300 • www.omron.com.br

OMRON ELECTRONICS MEXICO SA DE CV • HEAD OFFICE

Apodaca, N.L. • 52.811.156.99.10 • 001.800.556.6766 • mela@omron.com

OMRON ARGENTINA • SALES OFFICE

Cono Sur • 54.11.4783.5300

OMRON CHILE • SALES OFFICE

Santiago • 56.9.9917.3920

OTHER OMRON LATIN AMERICA SALES

54.11.4783.5300

© 2009 Omron Electronics LLC

Cat. No. X301-E-01A

02/10

Specifications are subject to change without notice.